



SED/Winged "C" 6550C High Performance Audio Beam Power Pentode



Characteristics

Electrical

Heater:	Min.	Nom.	Max.	
Voltage (AC or DC)	5.7	6.3	6.9	V
Current		1.6		A
Cathode:	Oxide-coated, unipotential			
Cathode-to-heater potential, max.			-300*/200**	V
Direct interelectrode capacitances, max.***				
Grid no.1 to cathode and grid no.3, grid no.2, base sleeve and heater			18.5	pF
Plate to cathode and grid no.3, grid no.2, base sleeve and heater			12.5	pF
Grid no.1 to plate (max)			1.1	pF

Mechanical

Operating Position	Any			
Base	Large wafer octal 8-pin with metal sleeve			
Maximum dimensions:				
Height	116 mm (4.57 in.)			
Seated height	106 mm (4.173 in.)			
Diameter	46 mm (1.81 in.)			
Cooling	Convection cooled			
Envelope Temperature (max)	250°C			
Approximate net weight	100 g (3.5 oz.)			

AF Power Amplifier, Maximum ratings

DC plate voltage	680	V
Grid no.2 DC (screen) voltage	400	V
Grid no.1 (control) voltage	-300	V
DC cathode current	175	mA
Plate dissipation	35	W
Grid no.2 (screen) dissipation	6	W

*Max with heater negative to cathode

**Max with heater positive to cathode

***Without external shielding

SED Outline drawing

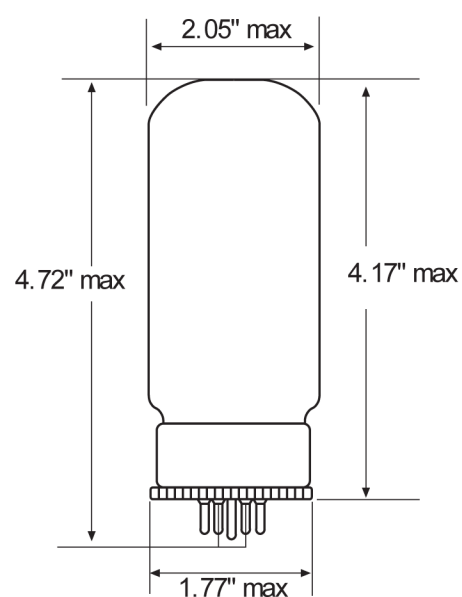

Base pin connections bottom view

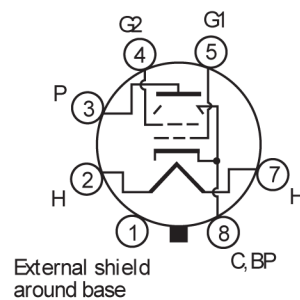

SED/Winged "C" 6550C High Performance Audio Beam Power Pentode



Typical Operation Class A₁ (single tube)

DC plate voltage	400	V
Grid no.2 DC (screen) voltage	225	V
Grid no.1 DC (control) voltage	-22	V
Peak AF grid no.1 (control) voltage	22	V
Zero-signal plate current	87	mA
Max signal plate current	105	mA
Zero signal grid no.2 (screen) current	4	mA _{dc}
Max signal grid no.2 (screen) current	18	mA
Transconductance (nominal)	9500	μS
Load resistance	3000	ohms
Signal output at 5% distortion	12	W

